

Guide to Motor Caravan Distributed Intelligence System

2007-2008

Model AS TTK v. 2.1



ArSilicii s.r.l.

Cautions

The material contained herein is the property of ArSilicii S.r.l. and may not be reproduced either photostatically or electronically or in any other way without the prior written permission of same.

ArSilicii S.r.l.

Via Sardegna, 11
Località Fosci
53036 Poggibonsi (SI)
ITALY

AssistenzaTecnica@ArSilicii.com

<http://www.ArSilicii.com>

tel. +39.0577.988316

fax +39.0577.988449

The manufacturer declines any liability for damages to persons or property deriving from the information contained herein or due to improper use of the material described and may make changes to the products also without prior notice.

CAUTIONS	2
INTRODUCTION	5
SYSTEM STRUCTURE	5
CONTROL UNIT MODEL CP5-TTK	8
<i>FUSE ALARM WARNING LIGHTS</i>	3
FLASHING QUICKLY: APPR. TWICE A SECOND.	4
WHAT TO DO IF	5
CONTROL PANEL STRUCTURE AND HOW IT WORKS	7
Navigation rotor.....	7
Quick Keypad.....	8
<i>LCD Viewer</i>	10
Icons.....	10
GRAPHIC BARS.....	12
LINE 1 AND LINE 2 (ALPHANUMERICAL CHARACTERS).....	12
DETAILED DESCRIPTION OF THE FUNCTIONS	13
<i>Functions</i>	13
PUMP.....	13
CLOCK.....	13
LIGHTS.....	13
LEVELS.....	14
GAS-SOLENOID VALVE.....	15
BATTERIES.....	15
TEMPERATURES.....	16
HEATING.....	16
BOILER.....	16
FRIDGE.....	16
220V MAINS.....	17
LANGUAGES.....	17
ALARMS.....	17
SOLAR PANELS.....	18
DETAILS ABOUT THE STRUCTURE OF THE AS TTK SYSTEM	19
DESCRIPTION OF THE SYSTEM.....	19
DESCRIPTION OF THE WIRING.....	19
<i>Power-Link connections</i>	21
<i>Power supply unit connections</i>	21
<i>Distributor connections</i>	21
<i>Control panel connection</i>	22
<i>TTK pump node and level sensors connection</i>	22
<i>Power Hub – Services connection</i>	22
<i>Ceiling Power Hub – Display and control panel connection</i>	22
ADVICE FOR MAINTENANCE :.....	22
FEATURES OF POWER SUPPLY UNIT MODEL AL-C20	23
SPECIFICATIONS.....	23
<i>Electrical</i>	23
<i>Size</i>	23
<i>Connections</i>	23
CONFORMITY.....	23
PRACTICAL ADVICE FOR USE.....	23
<i>Set-up</i>	23
<i>Taking out of service</i>	24

<i>Do not:</i>	24
TTK POWER-LINK 2 NODE FEATURES	25
DESCRIPTION.....	25
<i>Inputs</i>	25
<i>Outputs</i>	26
LOGIC LAYOUT	28
POWER HUB TTK FEATURES AND HOW IT WORKS	30
MODEL PH2-TTK.....	30
<i>Inputs</i>	30
<i>Outputs</i>	30
ELECTRICAL SPECIFICATIONS.....	31
FEATURES OF NODE MODEL NSA10.....	32
MODEL NSA 10	32
<i>Inputs</i>	32
<i>Outputs</i>	32
ELECTRICAL SPECIFICATIONS.....	32
CONNECTORS	33
SOLUTION TO THE MORE COMMON PROBLEMS	34

Introduction

This guide contains information about the distributed intelligence system developed by ArSilicii and it is structured as follows:

- Instructions for use of the control unit and basic principles. This section contains everything the user needs to obtain the benefits of this system.
- Detailed description of the system components and how they are connected, intended for the dealer or the more expert user for repairs or particular installations.
- Guide to solving the most frequent problems.

System structure

The distributed intelligence system referred to herein is a modern and completely innovative electrical system. The basic feature that differentiates this system from conventional ones is the possibility of data transmission on a special cable called “bus”.

The data in question are those associated with the vehicle operating parameters, such as voltage of the batteries, or the level of a tank or certain data for diagnosing the correct operation of all the devices on board.

The system is open, i.e. the vehicle can be customised according to requirements.

Installing certain optional kits, it is possible to easily and quickly add new functions that are fully integrated in the system.

As the structure of this type of system differs from the conventional one, a brief description of the operating principles is required to allow the end user to be able to completely exploit the potential it offers.

The following figure shows the simplified logic layout of the system wiring.

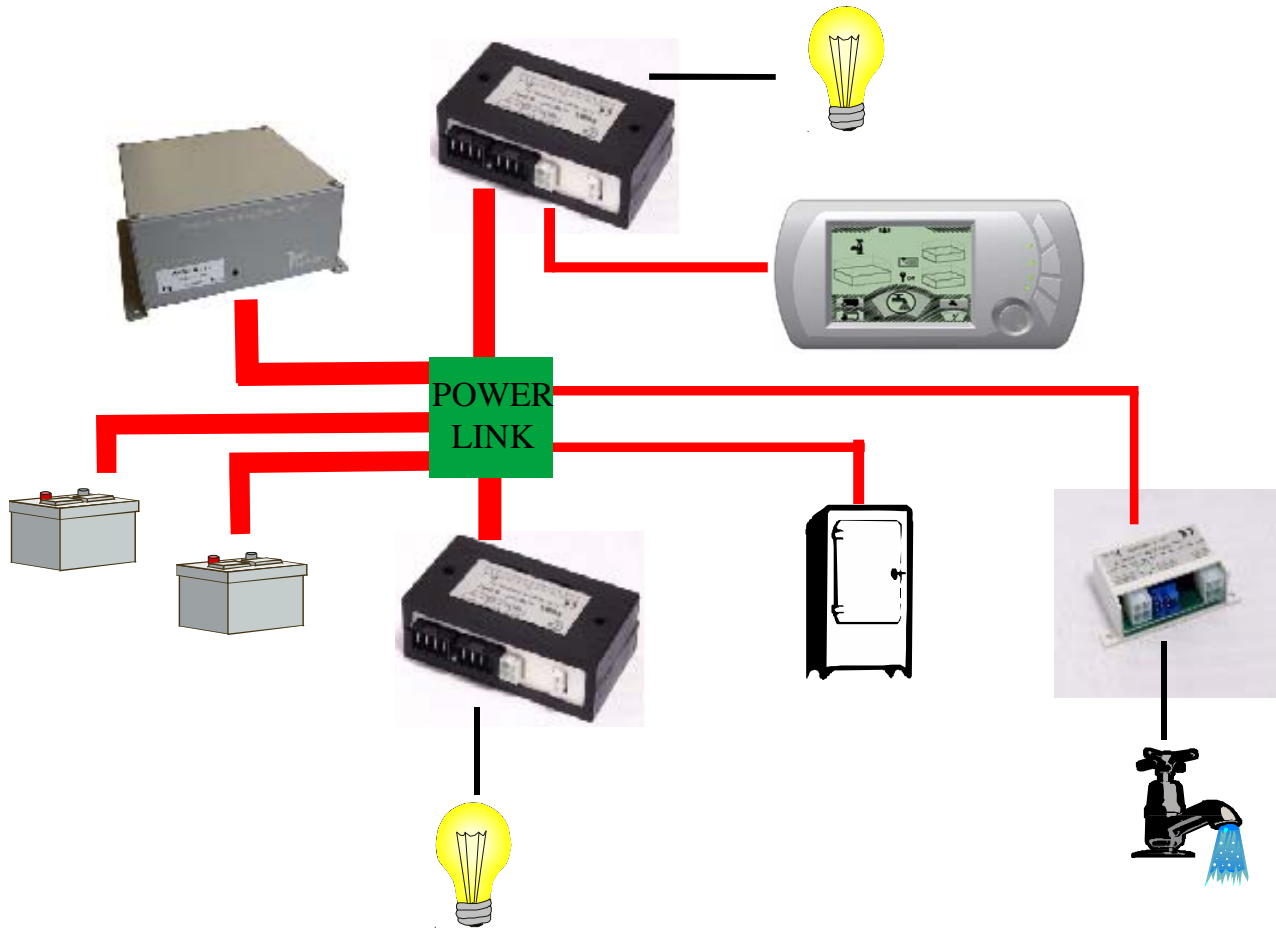

The main parts of the system shown above are the following:

- Control panel
- Distributors
- Power-Link
- Power supply unit
- Pump and levels node
- Wiring

In the pages that follow, we shall refer to the devices connected on the bus generically as “nodes”. The **node** is an electronic board capable of conversing on the bus. The nodes can control the activation of electrical devices connected to them and check their operating status. Through the bus it is also possible to communicate with all the other nodes present in the motor home.

The **Power supply unit** is a device that transforms the mains voltage (220 Volts or 110 Volts depending on the country) into suitable current for charging the batteries.

The **Power-Link** is a node capable of handling the flows of energy passing from the power supply unit from/to the batteries and to the services via the distributors. This node continuously checks the voltage of the batteries and also controls the fridge depending on the operating conditions of the vehicle engine.

The **control panel**, also called control unit, is a particular node that can view the information exchanged through the bus in a manner that the user is able to understand.

Through this node, it is possible to learn the operating status of the various parts of the motor caravan, and control the switching on or off of certain other nodes.

The **distributors** are nodes through which the energy leading from the batteries is distributed via the Power-Links.

The distributors subdivide the energy on the various loads connected to them extremely safely and they limit it to prevent hazards in the event of a short circuit.













For this purpose non-destructive protections are used, which are triggered in the case of a short circuit and are restored once the cause has been eliminated, with no need for any further action or fuse replacement.

As mentioned previously, the distributors too, are under the control of the control unit via the bus. In the system in question, generally only one distributor is installed to which the loads located near the ceiling such as ceiling lamps and light fittings in general are connected. The loads located on the floor, such as heater and boiler, are connected directly to the powerlink.

Another standard node is the **pump node**, which turns the water pump on and off and checks the level of the fresh water and of the drain water tanks.

CONTROL UNIT Model CP5-TTK



	Control unit and electric system on/off button.
	Interior lights on/off button.
	Water pump supply button.
	Tank and battery level test button.
	Additional option function button.
	Engine battery voltage led bar
	Services battery voltage led bar
	Fresh water level led indicator bar.
	Drain tank full warning light
	220 V mains warning light / Battery charger fuse
	Floor line fuse alarm warning light / Pump self-restoring fuse
	Ceiling Line fuse alarm warning light / Solar panel fuse
	Fridge line fuse alarm warning light / Sidemarker self-restoring fuse



MAIN ON/OFF BUTTON:

Pressing this button will turn the control unit on or off.

Turning on the control unit activates the distribution of energy to the lower part of the living quarters, while turning it off will deactivate **all** the services controlled by the system (e.g. ceiling distributor, pump, low level services).

Note:

When the control unit is turned on all the LEDs will light up for about half a second to check that they are working properly. To avoid surprises, while doing this it is always wise to carefully watch the status of the LEDs.

Warning light LED:

When the control unit is on, the led above the ON button notifies the following conditions:

Warning light on	Low level services on
Warning light off	Low level services off
Warning light flashing	Short circuit on a low level service



LIGHT BUTTON:

Pressing this button activates the outputs of the ceiling distributor that control the interior lights.

Warning light LED:

The status of the warning light associated with this button reflects the status of the ceiling distributor outputs:

Warning light on	At least one ceiling distributor service on (e.g. outside light).
Warning light off	All the ceiling distributor services are off
Warning light flashing	Short circuit on one of the ceiling distributor services



WATER PUMP BUTTON

Pressing this button will turn on the pump connected to the pump node output.

Warning light LED:

The status of the warning light associated with this button reflects the status of the pump.

Warning light on	Pump on
Warning light off	Pump off
Warning light flashing	Pump short circuit.



INFO BUTTON

Pressing this button will show battery and water level status information on the LED indicators.

Warning light LED:

The warning light located above this button flashes when the battery voltage levels are too low (below 9V) or when the fresh water level sensor is not working properly.

LEVEL LED BARS:

After pressing the INFO button the led bars show the status of the batteries and fresh water tank, with the following meaning:

Battery level indicators:

1st GREEN LED	on for voltage over 12.5 Volts.
2nd GREEN LED	on for voltage over 11.5 Volts.
3rd GREEN LED	on for voltage over 10.5 Volts.
4th RED LED	on for voltage over 10.5 Volts.
4th RED LED	flashing for voltage below 9 Volts.

Fresh water tank level indicator:

1st GREEN LED	Level over 75%.
2nd GREEN LED	Level over 50%.
3rd GREEN LED	Level over 25%.
4th RED LED	Level below 25%.
4th RED LED	Flashing, problem on level rod reading

When the batteries are being charged with the engine on, the led bars that indicate the voltage levels turn on in sequence up to the voltage measured. If the bar that indicates the voltage of the services battery is stationary, this means that the two batteries are not in parallel.



220V MAINS WARNING LIGHT

This is on when the power supply unit is connected to the electricity mains.

If the **warning light of this button flashes** it means that the fuse on the Power Link associated with this line has burnt.



DRAIN TANK LEVELS WARNING LIGHT

This flashes when the recovery tank level is full.

FUSE ALARM WARNING LIGHTS

These are on when a fault is detected in the fuses on the Power Link.

These warning lights are the following:



- Floor line fuse alarm warning light (flashing quickly)
- Pump self-restoring fuse alarm warning light (flashing slowly)
- Ceiling line fuse alarm warning light (flashing quickly)
- Solar panel fuse alarm warning light (where applicable) (flashing slowly)
- Fridge line fuse alarm warning light (flashing quickly)
- Sidemarkers self-restoring fuse alarm warning light (flashing slowly) **FIAT vehicles only**

flashing quickly: appr. twice a second.
flashing slowly: appr. once every 2 seconds.

WHAT TO DO IF....

The control unit fails to turn on when the button is pressed.

- Check that the connector behind the control unit is plugged in correctly, if necessary check if there is battery current between the RED wire and the BLACK wire.
- Contact the competent personnel.

The control unit turns on but the distributing elements are not activated.

- If the control unit turns on and off correctly but the distributing elements remain fixed in one status and it is possible to only turn the lights on and off with the entrance switch, it is no longer possible to control the pump. Also in this case, check that the connector behind the control unit is plugged in correctly, paying particular attention to the orange and grey wires.
- Contact the competent personnel.

A LED does not turn on even if the situation would require it to do so.

- Turn the control unit on and off to see if the LEDs are working properly.
- Contact the competent personnel.

The 220V MAINS warning light fails to turn on.

- Check if the outside socket is connected to the 220V mains.
- Turn the control unit on and off to see if the LEDs are working properly.
- Check if the differential switch located in correspondence with the socket but inside the living quarters is on.
- Check that the power supply unit plug is inserted correctly in its socket.
- Contact the competent personnel.

The red LED of the water tank level indicator flashes.

- Low water level.
- If the pump turns on and off normally but pressing the water tank level button the bottom red LED flashes, try cleaning the level sensor rods, which might be dirty.
- Contact the competent personnel.

The bottom red led of the engine battery indicator flashes.

- Check whether the engine battery is damaged.
- The fuse next to the engine battery positive terminal might be broken.
- Contact the competent personnel.

It is impossible to turn on the lights and the control unit is on and working perfectly.

- If the control unit shows all the indications and controls the pump but the lights do not turn on, try turning the lights on from the button panel near the entrance door ⁽¹⁾ or turn the control unit off and on again.
- Contact the competent personnel.

Note 1:

The button panel at the entrance controls the lights directly at the ceiling distributor without passing through the control unit. For this reason it is possible to turn the lights on and off using the button panel also with the control unit off.





CONTROL PANEL STRUCTURE AND HOW IT WORKS

*Model: Rimor 2005 PR0445B
v050822*



CONTROL PANEL MAIN COMPONENTS.

In addition to the LCD viewer the control panel has 4 buttons and a navigation rotor.

P1	
P2	
P3	
P4	
J1	

Navigation rotor

The navigation rotor J1 is used to move the focus of the choice among the icons. Turning it to the left or right you can scroll to select the various icons. Positioning on a generic icon, once it has

been pressed the specific menu is accessed. Turning it again scrolls all the properties and/or methods of the generic icon.

If a command is to be given within the generic menu, keep the rotor pressed and turn it to the right or left to give the command.

Example: Switching the water pump on or off:

Turn the cursor until the focus is positioned on the tap icon, press the rotor (this selects the symbol) additional information appears in the form of alphanumerical characters. In this case the word PUMP is shown (line 1) and its status ON/OFF (line 2).

Keeping the rotor pressed, turning it to the right or left selects the required status to be set on the PUMP: ON/OFF

Simply pressing it takes you back to the navigation mode.

Turning it without keeping it pressed scrolls the menu items: PUMP, PROTECTION, and PROBLEMS.

Simply pressing it takes you back to the navigation mode.

Positioning on the word PROTECTION still keeping the rotor pressed, turning it to the right or left selects the required status to be set for the PUMP PROTECTION: ON/OFF

Simply pressing it takes you back to the navigation mode.

Positioning on the word PROBLEMS keeping the rotor pressed, turning it nothing will happen because this is not a menu from which we can make controls or choose statuses, it is only possible to view the status of the pump electrical protection.

Simply pressing it takes you back to the navigation mode.

Quick Keypad

This comprises four keys on the right-hand side of the LCD viewer.

Each key has a little light (also called LED), which shows the status of the icon on it. Now let's see the functions connected with these keys in detail.

P1	Control unit switching on and off. When the control unit is switched on all the low level services are activated. When it is switched off all services are switched off, also those of the ceiling distributor.
Led P1	Indicates the status of the floor services with the control unit on. The flashing led indicates a short circuit on a low level service.
P2	This indicates the general lighting switch and allows you to cut off or supply power to all the lights present on the ceiling of the vehicle living quarters. Green light ON = CEILING DISTRIBUTOR on, OFF = CEILING DISTRIBUTOR off.
Led P2	With the control unit on it indicates the status of the ceiling distributor services. The flashing led indicates a short circuit on a ceiling distributor service.
P3	This is the remote button for turning the pump on or off. Green light on = PUMP ON, off = PUMP OFF
Led P3	With the control unit on it indicates the pump status. The flashing led indicates a short circuit on the pump.

P4	Any auxiliary device.
----	-----------------------

LCD Viewer

The structure of the LCD viewer is the one shown in Figure 1:

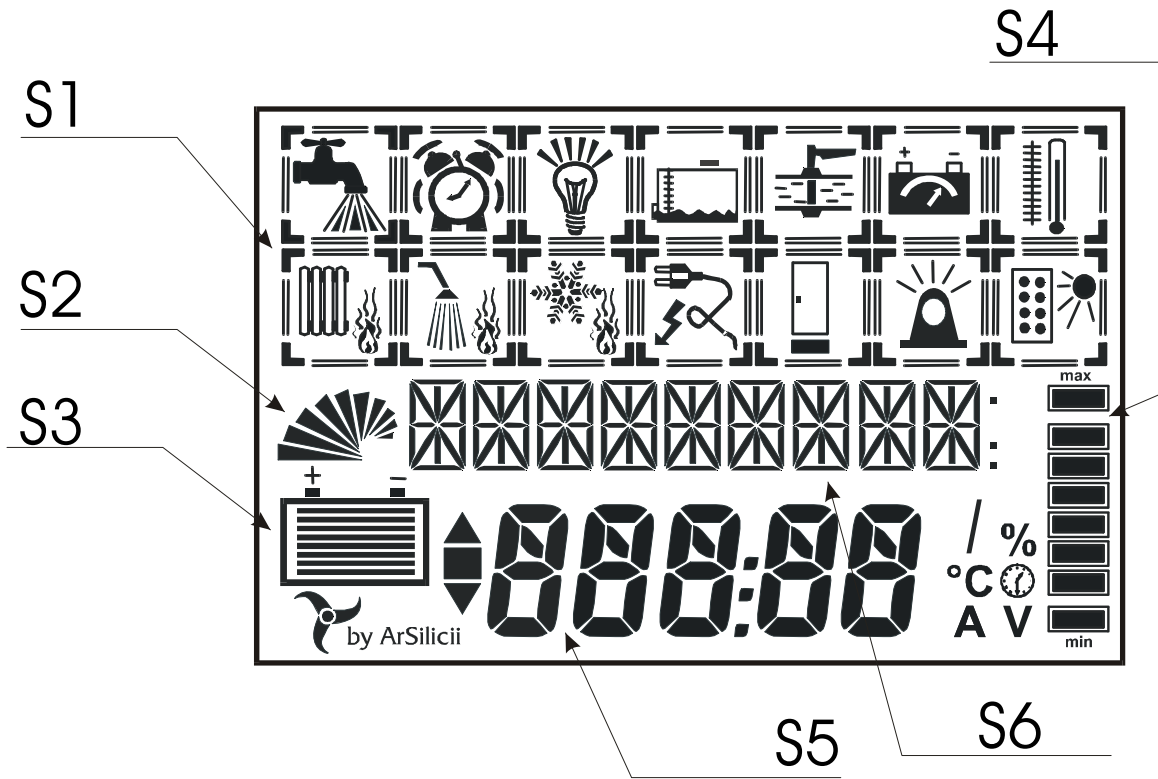

Figure 1

S1	Icon
S2	Bar No.3
S3	Bar No.2
S4	Bar No.1
S5	Line No.2
S6	Line No.1

The top part of the display graphically shows the symbols that characterise the main function areas offered by the system; these are called icons.

Immediately below, there are two lines of alphanumerical characters (Line 1 and Line 2), which describe the various items of the menu selected. At the sides of the LCD display, there are graphic bars, which allow immediate and constant viewing of the basic values (e.g. services battery level, instantaneous current taken in by the system, etc.).

Clearly, not all the graphic symbols shown in the previous figure can be seen at the same time.

Icons

There are fourteen icons, which schematically represent all the control panel functions.

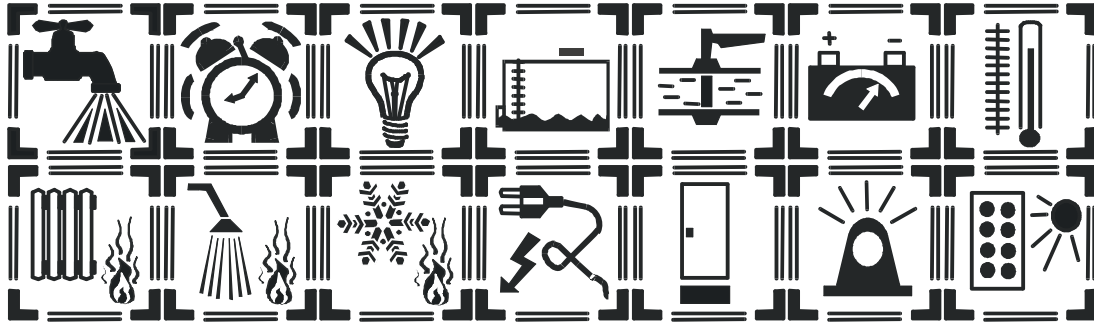

Each icon comprises four parts (Main Body, Secondary Body, Corners and Bars), which can be viewed or not depending on the cases.

The icon shown in the figure, at the top left of the viewer, is associated with the water pump.

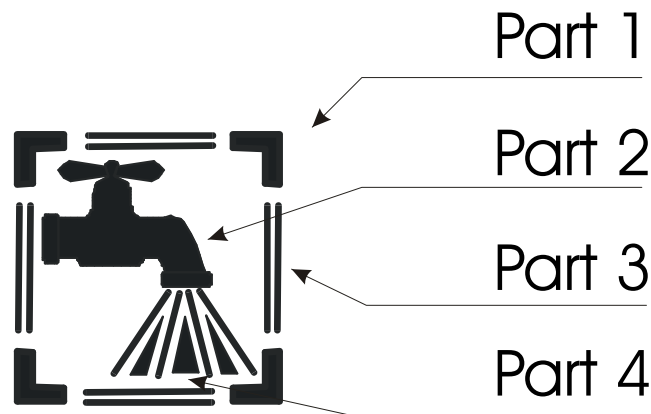

Figure 2

Part 1	Corners
Part 2	Main body
Part 3	Bars
Part 4	Secondary body

The parts that form an icon like the one in Figure 2 are:

The **Main Body**, (the tap), indicates the function, in this case the water pump;

The **Secondary Body** (water) shows whether the function is operating or not. In this case, inside the icon the water can be seen coming out of the tap only if the pump is on.

The **Corners** indicate the icon selected at the moment through the *navigation keypad*.

If the **Bars** are lit, they indicate an alarm status or a fault related with that function group (in this case, for example, it could be a short circuit on the pump).

GRAPHIC BARS

There are three graphic bars, Figure 3, which give an evaluation “at a glance” (as they are always visible regardless of the current operating mode) of the main data concerning the camper. This information can be examined in more detail in the associated items of the menus provided.



Figure 3

Bar 1	Bar No.1	Bar 1 indicates the <u>level of the fresh water</u> The min. and max. levels respectively indicate: fresh water tank <i>Empty</i> and fresh water tank <i>Full</i> . For more accurate information, select the tank symbol and consult the menu provided.
Bar 2	Bar No.2	Bar 2 indicates the <u>battery charge level</u> In this case, too, more accurate information can be obtained selecting the associated symbol and consulting all the menus it contains.
Bar 3	Bar No.3	Bar 3 indicates the <u>instantaneous current intake</u> of the service battery. Its filling takes place <u>counter-clockwise</u> , a higher number of segments indicates higher intake.

LINE 1 AND LINE 2 (ALPHANUMERICAL CHARACTERS)

The area used for showing the characters and numbers is subdivided on two lines. Their behaviour varies depending on whether a symbol is selected or not.

If we are in navigation mode (no symbol selected), the top line will be off completely, while the bottom one shows the time. In the opposite case, the top line shows the name of the menu item, while the bottom one shows the alternatives to it. Sometimes, if the symbol selected is associated with a quantity (e.g. with the battery or tank), the top line shows its name and the bottom one shows the value with the unit of measure at the side.

DETAILED DESCRIPTION OF THE FUNCTIONS

In this section we are giving a detailed description of the functions present on the control unit. Please remember that some of them might not be present on the model in your possession, or refer to accessories that are not installed. For reasons of convenience, the functions are grouped according to the icons that contain them.

Functions

PUMP



This contains the items of the menus related with use and diagnosis of the water pump. The bars around the symbol are shown only in the case of short circuit on the pump. The running water indicates that the pump is ON.

PUMP: ON/OFF

This allows you to set the on or off status of the water pump. *Initially this item of the menu is at OFF.*

PROT. ON/OFF

Besides the electrical protection on the PUMP (which is always active due to the node), it is possible to set an additional one. If activated, this prevents the pump from switching on if there is not enough water in the tank. *Initially this item of the menu is at OFF.*

When the protection is on the control unit sounds two beeps each time the pump status changes (e.g. from on to off or vice versa)

PROBLEMS: NO/SC

This indicates whether there are electrical problems on the pump or not (NO = no problem, SC = Short Circuit).

CLOCK



This contains the items of the menus related with the clock. It allows you to set the current time using the left and right arrow buttons.

LIGHTS



This contains the items of the menus related with the ceiling power supply of the motor home. The bars around the icon are only shown in the event of an electrical fault related with the upper part of the electric system. The beams indicate that the ceiling lights or in any case the loads connected to the ceiling distributor output are being powered.

LIGHTS: ON/OFF

This allows you to switch off the ceiling distributor outputs and all the loads connected to the vehicle ceiling distributor output. *Initially this item of the menu is at ON.*

PROBLEMS: NO/SC

This indicates whether there are electrical problems in the ceiling or not (NO = no problem, SC = Short Circuit). Any symbol next to the wording SC provides extra information for locating the short circuit. In particular the following symbols are shown (Figure 4):

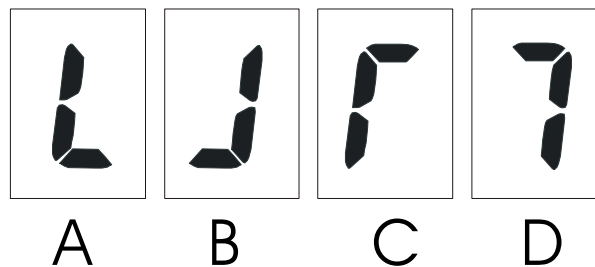

Figure 4

A+B	Short circuit on a low level service
C	Short circuit on the ceiling distributor left channel
D	Short circuit on the ceiling distributor right channel

In the event of more than one source of short circuit there is the combination of the symbols shown above. As mentioned previously, when the cause of the short circuit ceases, the warning ceases and the systems resume correct operation without fuse replacement.

LEVELS



This contains the items of the menus related with the tanks. The bars can indicate: lack of fresh water or overflow of one of the recovery tanks.

FRESH: X %

This item of the menu shows the level of the fresh water tank expressed in percentage of the total volume. (for a sensor with 4 levels (0%-30%-60%-90%))

FRESH2: X %

This item of the menu shows the level of the additional fresh water tank expressed in percentage of the total volume. (for a sensor with 4 levels (0%-30%-60%-90%))

DRAIN 1: NO/FULL

Indicates whether the drain recovery tank 1 is full or not.

DRAIN 2: NO/FULL

Indicates whether the drain recovery tank 2 is full or not.

GAS-SOLENOID VALVE



Functions that can be activated only by the installation of optional kit.

This contains the items of the menus related with the protections against gas leaks and the presence of carbon dioxide and it indicates the status of the gas solenoid valve.

GAS SENS : ON/OFF/GAS/--

The dashes (--) indicate that the sensor is not installed or is not working properly. The word ON flashing means that the sensor is warming up, and is therefore unable to detect an alarm situation. The word ON stops flashing when warm-up has been completed.

The word GAS appears when an alarm situation has occurred, i.e. there is a gas leak.

ALR BUZZ: ON/OFF/--

The dashes (--) indicate that the sensor is not installed or is not working properly. The ON control enables the buzzer on the sensor to sound in the case of alarm, while the OFF one disables it.

BATTERIES



This contains the items of the menus related with the measurements of the voltage rates on the two batteries (engine and services), of the current delivered and of the charge quantity stored.

The bars indicate that the services battery is starting to get damaged.

SERV BATT : X V

Indicates the voltage, expressed in Volts, at the terminals of the services battery.

ENG BATT: X V

Indicates the voltage, expressed in Volts, at the terminals of the engine battery.

Functions present on some versions only:

CURRENT1: X A

Shows the rate of the current delivered instantaneously by the floor distributor on the loads connected to it expressed in Amperes.

TEMPERATURES



Functions that can be activated through suitable optional kits:

This contains the items of the menus that indicate the momentary value of the inside and outside temperatures.

IN TEMP : X °c / --

Indicates the temperature expressed in degrees centigrade, inside the living quarters. The dashes indicate that the sensor is not installed.

EXT TEMP : X °c / --

Indicates the temperature expressed in degrees centigrade, outside the living quarters. The dashes indicate that the sensor is not installed.

HEATING



This contains the items of the menus for remote control and timing of the electronic heater.

Function not active in this model.

BOILER



This contains the items of the menus for remote control and timing of the boiler.

Function not active in this model.

FRIDGE



This contains the items of the menus for fridge control.

Function not active in this model.

220V MAINS



This contains the items of the menus related with the presence of the 220V outside mains and with the power unit.

The bars indicate a high temperature inside the switching power unit.

The stroke of lightning indicates connection to the 220V mains.

EXT PWR: ON/OFF

Indicates whether the vehicle is connected to the 220V mains or not.

Functions present on some versions only:

PARALLEL : ON/OFF

This allows you to decide, **if the vehicle is connected to the 220V mains**, to put the engine battery in parallel with the services battery. *Initially this item of the menu is at OFF.*

LANGUAGES



This contains the items of the menu with which you can choose the language (ITALIAN, ENGLISH, FRENCH, GERMAN and SPANISH), in which all the information will be shown.

ALARMS



This contains the items of the menus associated with the alarms present in the motor home, in this model the status of the power link fuses is shown.

The flashing beams indicate the presence of any broken fuse.

There are two menus, Fuses and Fuses2.

The first concerns those on the upper part of the PowerLink accessible by the user.

The second concerns the self-restoring ones inside the PowerLink and the engine battery fuse.

Menu:

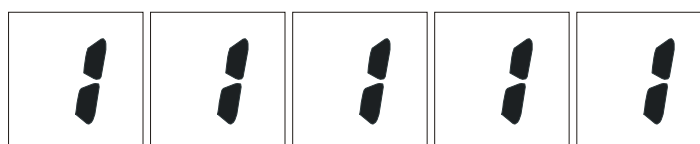

F5

F4

F3¹⁷

F2

F1

FUSES

For the map of the fuses, refer to the chapter on the PowerLink.
The segment associated with the blown fuse flashes.

Menu:

FUSES2

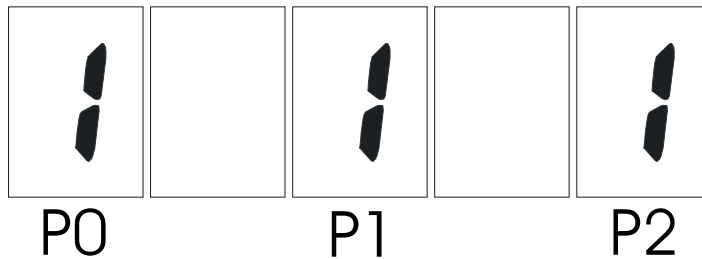

- P0 Sidemarker power supply self-restoring fuse (FIAT only) yellow connectors.
- P1 Pump node power supply self-restoring fuse red connector.
- P2 Engine battery fuse.

The segment associated with the blown fuse flashes.

SOLAR PANELS

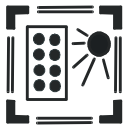

This contains the items of the menus associated with the solar panels.

Functions that can be activated through appropriate optional kits:

The presence of the sun symbol (top right) indicates that the battery charger internal regulator is on. The absence of it means that it is off, therefore any flow of energy deriving from the solar panel is not allowed.

SOLAR P: ON/OFF

This allows you to turn the solar panels on or off. Panel ON/OFF

DETAILS ABOUT THE STRUCTURE OF THE AS TTK SYSTEM

Description of the system

This introductory document describes the structure of the AS TTK system. For details about the types of connectors and specifications for the cable sizes, reference should be made to the chapters that follow.

The base AS TTK system substantially comprises 4 devices, a power supply unit model AL-C20, a TTK PowerLink, one distributor for distribution and protection of the ceiling services (model PH2-TTK-Cielo); there are also a display and control panel, and an actuator node for the water pump, TTK Pump node.

Description of the wiring

Owing to the technology at the basis of the AS TTK system, the devices that form it can be located in the best position according to the vehicle layout, as there are no particular wiring routing restraints. No maintenance operations are necessary and there is decidedly less wiring than with conventional systems.

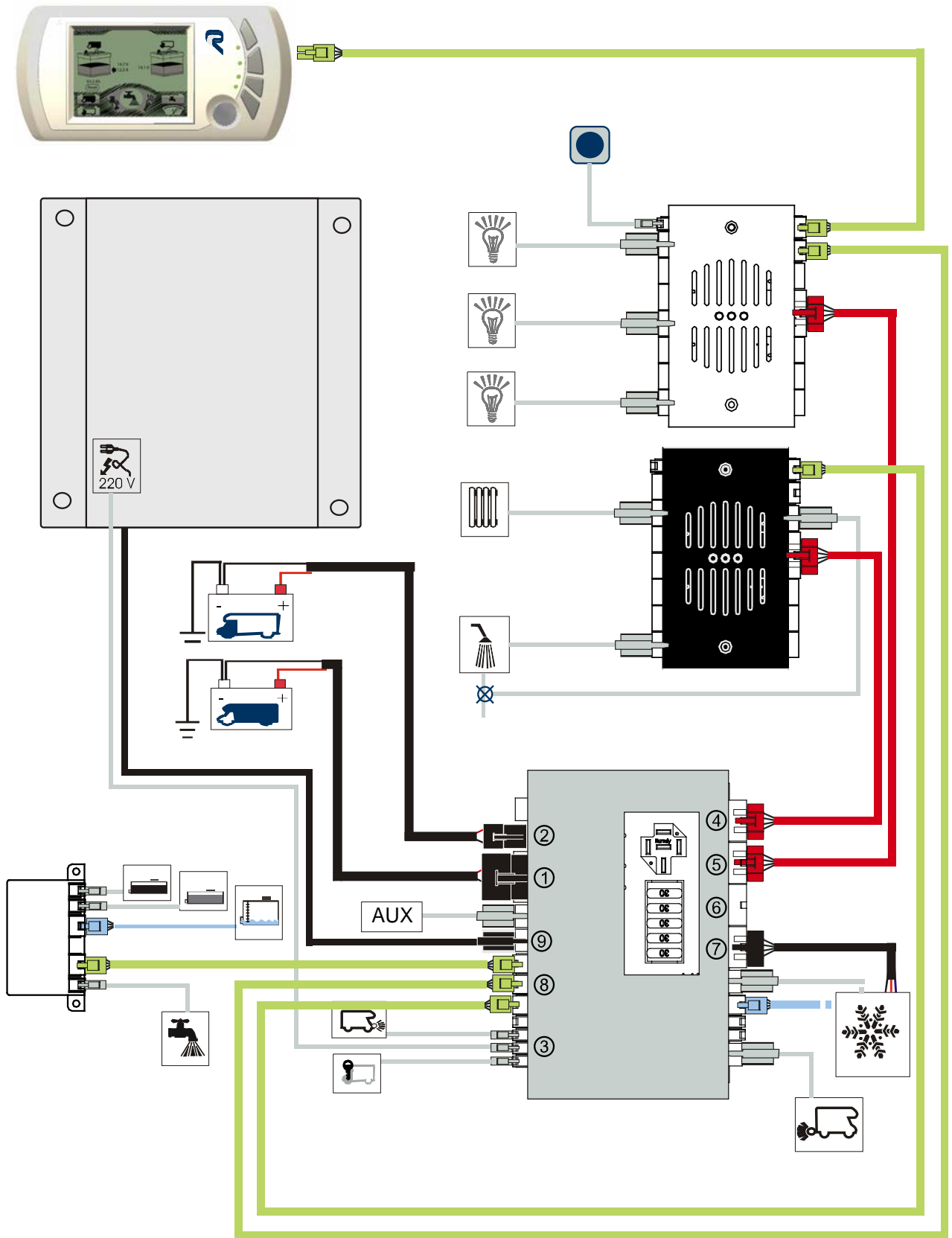

By ArSilicii

Figure 5 "Overall system view "

Figure 5 shows the overall view of the whole AS TTK system the connections shown above are described on the pages that follow.

Power-Link connections.

The Power-Link is the block located at the bottom of the figure and it is exactly the point that links the system power. A detailed description follows of the layout and the various connections that involve this node.

The connection of the services battery positive terminal with the Power-Link (①) is made with a cable with a large diameter and it is subjected to a fuse of adequate cut-off power, housed in a reed fuse carrier located in the vicinity of the battery itself, in series with the positive terminal.

The positive terminal of the engine battery is also taken to the Power-Link (②), with a large-sized cable to allow connection in parallel to the services battery for charging the two batteries in conjunction when there is an external power source.

The negative terminals of the batteries are connected to the chassis and to the screw connector on the opposite side of the board.

The six-pin connector (③) comprises the vehicle side lights on signal, the connection to the Power-Link of the engine on signal (D+), which uses the upper or lower contact depending on the type of vehicle. The 220V mains connection signal is connected in the upper contact of the 2-pin connector at the side of the 6-pin connector.

Lastly, the Power Link is connected to the power supply unit through a cable (④) with two wires. The connector marked AUX serves for an outside source of energy, such as the solar panel regulator output.

Then we find 4 connectors that serve to distribute the energy leading from the batteries to the inside of the vehicle.

On the opposite side, two connectors, each with 4 contacts (two double pins), are used for connections towards the distributors, while one (⑤) is dedicated to the connection towards the fridge.

Every connector can house one pair of wires or two, to be able to double the cable sizes and handle particularly heavy loads.

Another 3 connectors are provided (⑥) which serve as points of access to the bus, for exchanging information among the nodes. The first of these is dedicated expressly to connection of the pump node.

On the Power-Link there are 4 fuse carriers, which protect the same number of lines.

Power supply unit connections

The power supply unit is connected to the Power-Link via a power lead with two wires (④). The Power Link can charge the services battery alone or also the engine battery.

The Schuko plug through which the power supply unit is connected to the 220V mains, must be connected in its output to the differential circuit breaker that protects it and with the characteristic ground connection.

If connected to the mains, the power supply unit is a completely autonomous source of energy and can therefore deliver power even if the batteries are not present or damaged, or even if the battery fuses have blown. This feature offers the user a further guarantee of sturdiness.

Distributor connections

The distributors receive power through a cable with two wires that leads directly from one of the 2 outputs (④, ⑤,) of the Power-Link. For convenience each output is available in 2 connector formats, one high power and one low for loads that require less current.

In turn, the distributors supply energy to the services connected on the 8 outputs provided for this purpose, keeping the current delivered under control and coming into action in the event of a short circuit.

The distributors communicate with the other nodes via the bus to which they are connected with a cable that leads from one of the 4 signal outputs (⑤) of the Power-Link. In turn, the distributors repeat the bus on a signal connector to which the control panel or the pump node can be connected.

Fridge connection

There is a power connection (⑥) and a signal connection for connecting the fridge supply and control signals respectively.

Control panel connection

The control panel can be connected indifferently on the Power-Link or on one of the signal connectors on the distributors.

TTK pump node and level sensors connection

This type of connection is the one that exploits the potential of the AS TTK system. In fact, the loads or sensors are connected directly to the pump node, which can be located near to them and exploit the potential of the control panel for displaying the status of the objects connected and the actuation of them.

On the Power-Link there is an output (the first of the group of three) dedicated to the connection of the pump node.

Power Hub – Services connection

For the connections of the ceiling services to the ceiling Power Hub model PH2-TTK-Cielo, there are 8 connectors that repeat both poles.

Ceiling Power Hub – Display and control panel connection

The connection (point-to-point) of the ceiling Power Hub with the display and control panel must also be made using a cable with 4 wires, 2 of which for power (+12 and GROUND) and two for signal (BUS_A and BUS_B) headed with the special connectors.

Advice for maintenance :

- Do not operate on the system without firstly disconnecting the 220V mains, the solar panels and the batteries.
- Check the acid level of the batteries at routine intervals.
- During prolonged stops and garaging of the vehicle, in the lack of external power (220V mains or solar panels) it is advisable to disconnect the positive terminal of both the engine battery and the services battery.

FEATURES OF POWER SUPPLY UNIT Model AL-C20

The power supply unit model AL-C20 is a device conceived for being able to switch the power withdrawn from the mains adapted to recharge the batteries.

Specifications

Electrical

The electrical specifications of the device are:

- Supply voltage: 110-220 V, 50-60 Hz. according to regulations.
- Rated output power: 240 W @ 13.5 V.
- SMART active protections.
- If connected to the external 110/220V mains, the power supply unit delivers power even if the batteries are not connected
- **Optional:** Warning light

Size

Container: 195x165x85 Weight Kg. 1.4

Connections

- Cable (25 cm) for connecting to the 110/220 V external mains, with selector, 50 – 60 Hz with connector

Conformity

Statement of Conformity:	
The device meets the requirements of the Directives of the European Union: 89/336 EEC Electromagnetic Compatibility, 73/23 and 93/68 EEC Safety of electrical products.	
ArSilicii Srl Loc.Fosci, 25/F 53036 Poggibonsi (Siena)	
Product name:	Fuseless Switching MotorHome Power Unit Model : AL 310 X
Standards :	EN50081-1 EN50082-1 EN60335-1
Date	01/10/1999

Practical advice for use

Set-up

To set up the power supply unit, you are advised to proceed as follows:

- With the mains supply off, connect the Power supply unit and the Power-Link and the make the connection between the power supply unit and the wiring to the mains
- Connect the plug to the 220 V mains.

Taking out of service

- disconnect the plug from the 220 V mains
- disconnect all the connectors

Do not:

- carry out any maintenance work with the 220 V mains connected.

TTK POWER-LINK 2 NODE FEATURES

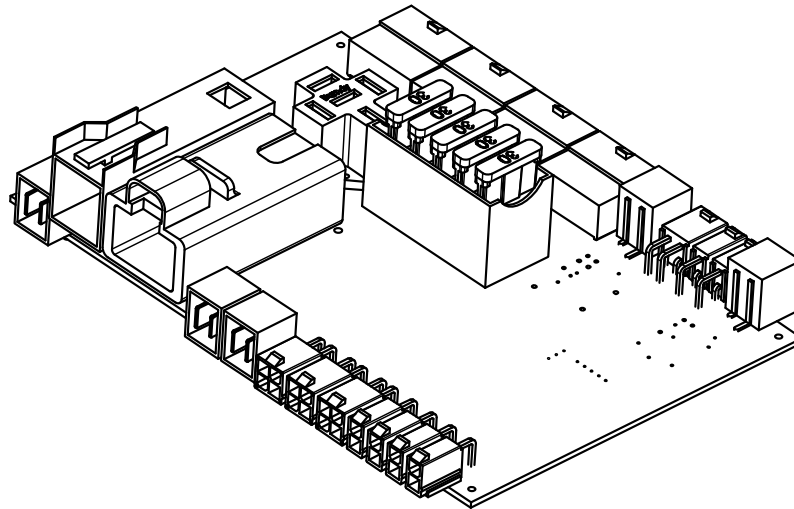

Description

This is the nodal point of the system; the main power sources converge here and are then distributed to the various services.

To avoid a reduction of the carrying power, the connectors to the energy sources can accommodate large-sized cables.

The board also has a set of fuses that protect certain outputs, and a relay that is easily replaceable, to put the services battery in parallel with the engine battery.

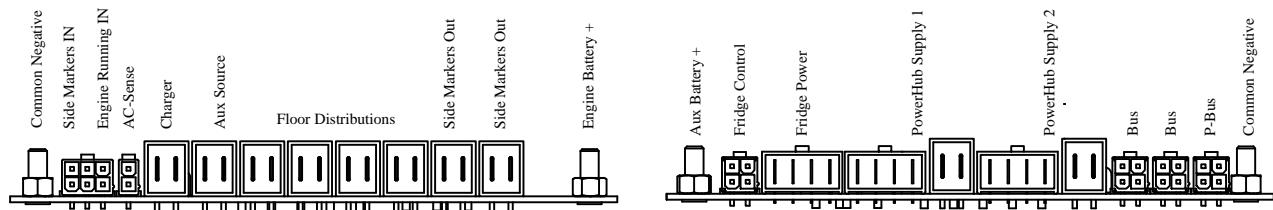

Inputs

The inputs can be divided into two groups: power and signal.







The power inputs are those related to the two batteries, the battery charger and possibly to an auxiliary source (AUX) such as solar panels; the signal inputs collect the status of the side markers, connection to the 220V or 110V network and the engine on signal (D+ or D-).

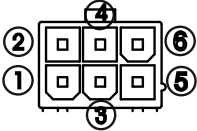

The data to/from the other devices are exchanged through the 3 connectors indicated as Bus. In particular, the first of the 3 (P-Bus) is expressly dedicated to connection with the pump node.

Outputs

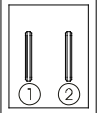
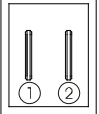
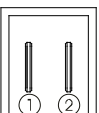
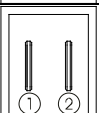
There are 2 connectors for connection to the distribution parts, PowerHub, two connections for supplying the fridge at 12V, and one for the fridge control signals, one signal active when the vehicle (D+) is switched on, and the outputs for the side marker lights.

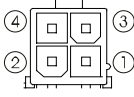
The table below lists all the connectors, in counter-clockwise order, with their polarity specifications, model and manufacturer.

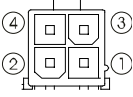
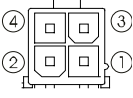
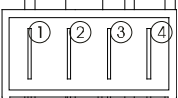
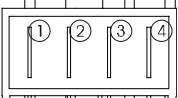
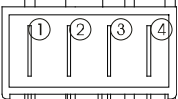
Connector (front)	Type	Name	Direction	Pin-Out
	M5 screw	Engine battery positive	IN	
	M5 screw	Services battery positive	IN	
	Molex "mini-fit Jr" MLX5569-06	Analogue signals	IN	<ol style="list-style-type: none"> 1. Signal at ground with lights on 4. Signal that goes to +12 V with ignition key turned 5. Signal that goes to ground with engine on. (Fiat, Ford) 6. Signal that goes to +12V with engine on. (Mercedes, Renault)
	Molex "mini-fit Jr" MLX5569-02A2	AC SENSE	IN	<ol style="list-style-type: none"> 2. +5V when 220V
	Lumberg "Rast 5" 3642 02 K02	CHARGER	IN	<ol style="list-style-type: none"> 1. Positive (+12). 2. Negative (Gnd).
	Lumberg "Rast 5" 3642 02 K02	-AUX	-IN	<ol style="list-style-type: none"> 1. Positive (+12). 2. Negative (Gnd).
4 X 	Lumberg "Rast 5" 3642 02 K02	4 X Power Outs	OUT	<ol style="list-style-type: none"> 1.Positive (+12). 2.Negative (Gnd).
	Lumberg "Rast 5" 3642 02 K02	SideMarkers OUT 2	OUT	<ol style="list-style-type: none"> 1.Signal (+12). 2.Negative (Gnd).
	M5 screw	Services battery negative	IN	
	Molex "mini-fit Jr" MLX5569-04	BUS	IN/OUT	<ol style="list-style-type: none"> 1. Bus B 2. Ground 3. Bus A 4. Positive +12 V

	Molex <i>"mini-fit Jr"</i> MLX5569-04	BUS	IN/OUT	1. Bus B 2. Ground 3. Bus A 4. Positive +12 V
	Molex <i>"mini-fit Jr"</i> MLX5569-04	P-BUS	IN/OUT	1. Bus B 2. Ground 3. Bus A 4. Positive +12 V
	Molex <i>"caimano"</i> MLX94213-2014	POWER HUB SUPPLY 1	OUT	1+2 Negative (Gnd). 3+4 Positive (+12).
	Molex <i>"caimano "</i> MLX94213-2014	POWER HUB SUPPLY 2	OUT	1+2 Negative (Gnd). 3+4 Positive (+12).
	Molex <i>"caimano "</i> MLX94213-2014	FRIDGE SUPPLY	OUT	1+2 Negative (Gnd). 3+4 Positive (+12).
	Molex <i>"mini-fit Jr"</i> MLX5569-02A2	FRIDGE CONTROL	IN/OUT	2. 12V if engine ON 2. Ground

Fuses

There are 5 fuses on the Power Link board, all with a capacity of 30A.

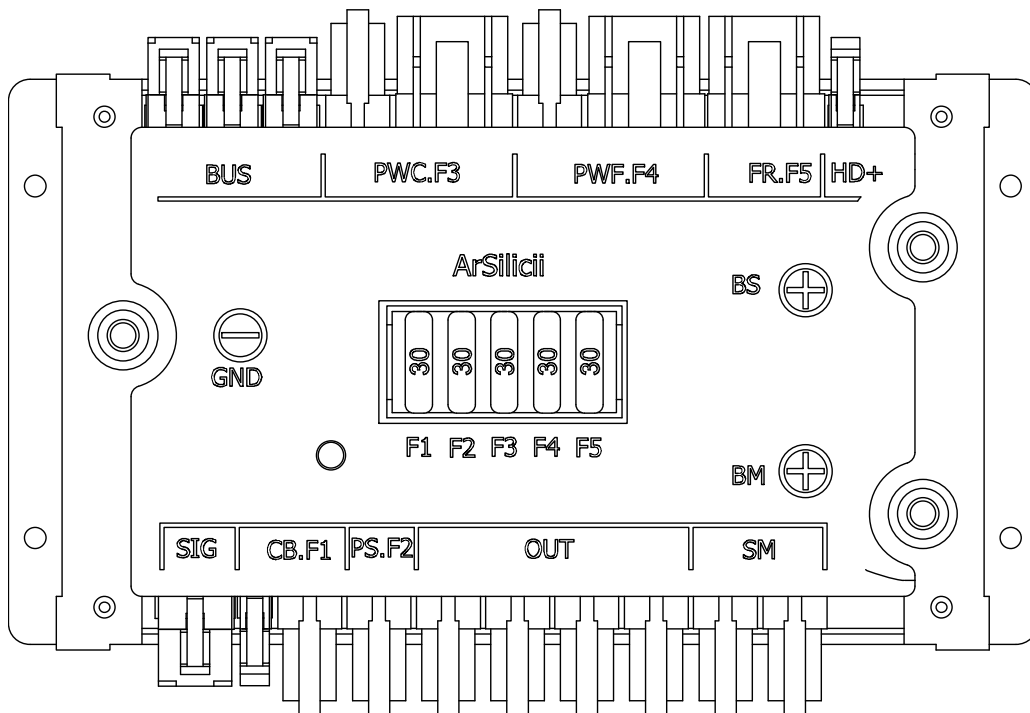

The table below shows their functions.

Position	Rating	Function
F1	30A	CHARGER input line protection
F2	30A	SOLAR PANEL input line protection
F3	30A	POWER HUB SUPPLY 2 output line protection
F4	30A	POWER HUB SUPPLY 1 output line protection
F5	30A	FRIDGE SUPPLY output line protection

Logic Layout

The diagram that follows shows the logic layout of the Power Link.

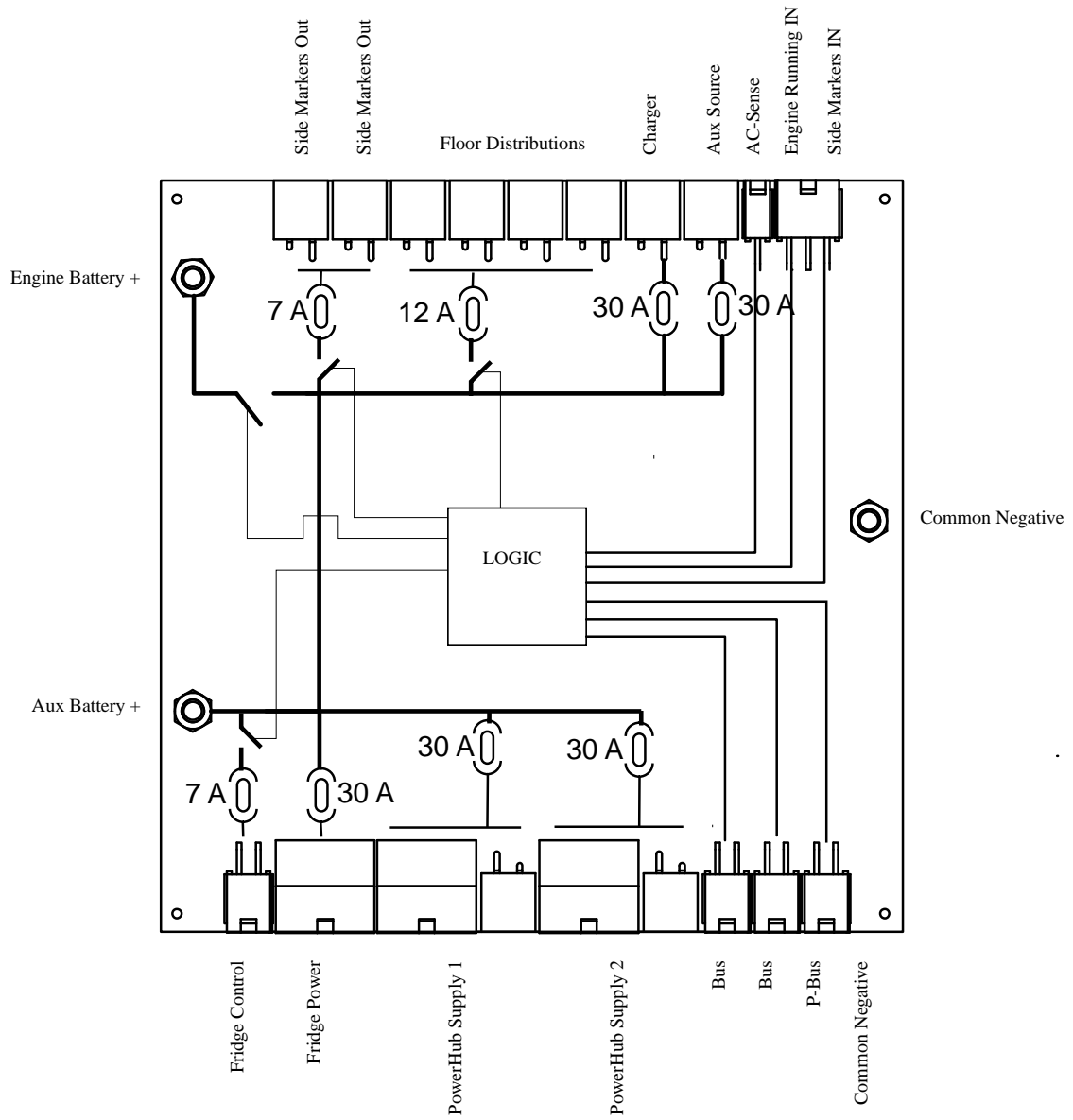

POWER HUB TTK FEATURES AND HOW IT WORKS

Model PH2-TTK

The power-hub, also called distributor, makes it possible not only to distribute energy and information to the various devices connected on its outputs, but also to protect them from any short circuits or abnormal overloads.

The distributor can be controlled to enable/disable the flow of energy to the outputs (G1, G2, G3 in the Figure) in two ways: locally, through a button (on/off) directly connected to the distributor (“INP” in the Figure), or remotely via the control unit, with a special control. The latter, depending on the models, can also display the status of the distributor electrical protections.

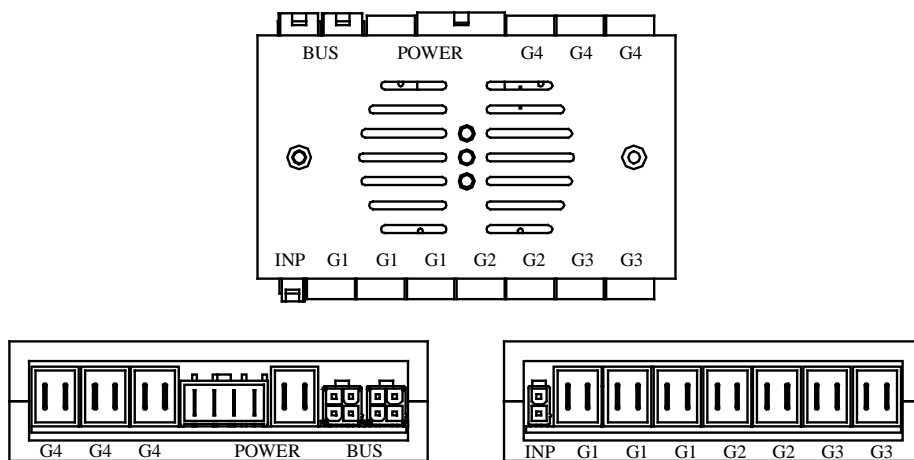

Inputs

The distributors have various types of input connections.

The supply is taken through the connectors marked in the figure with “POWER”. For convenience two different types of connector are available which accept wire sizes suitable for the different requirements.

In particular, there is a “*caimano*” 4-way connector with two contacts for each pin to increase the capacity.

Besides this, there is a two-pin connector for cases in which the power ratings involved are lower. The input marked “INP” is for a local button to switch the unit on or off.



The 4-pin connectors marked “BUS”, have two pairs, one powered (for very small loads) and the other for carrying information.

All the units that exchange information have a connection of this type to the BUS.

Outputs

The device has a set of connectors for the outputs (from G1 to G4) logically formed of 4 subgroups with two or three connectors each, which give a protected supply for the loads to be powered.

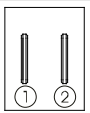
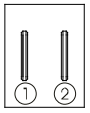
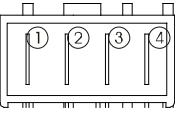
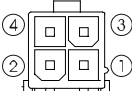
The following table summarises all the connectors used on the distributor with the manufacturers’ references should the need arise to make a new connection circuitry.

Connector (front)	Type	Name	Direction	Pin-Out
	Lumberg "Rast 5" 3642 02 K02	G1,G2,G3, G4	OUT	1. Positive (+12). 2. Negative (Gnd).
	Lumberg "Rast 5" 3642 02 K02	POWER	IN	1. Positive (+12). 2. Negative (Gnd).
	Molex "caimano " MLX94213-2014	POWER	IN	1+2 Negative (Gnd). 3+4 Positive (+12).
	Molex "mini-fit Jr" MLX5569-04	BUS	IN/OUT	1. Bus B 2. Ground 3. Bus A 4. Positive +12 V
	Molex "mini-fit Jr" MLX5569-02A2	INP	IN	Button between 1 and 2

Electrical Specifications

The electrical specifications of the device with reference to the Figure are the following:

- Supply voltage 12 V
- G1-G4 10 protected outputs divided into four groups, G1, G2, G3 and G4, each of them subjected to 12 A self-restoring fuses;
- IN control connector for sectionising the output groups.

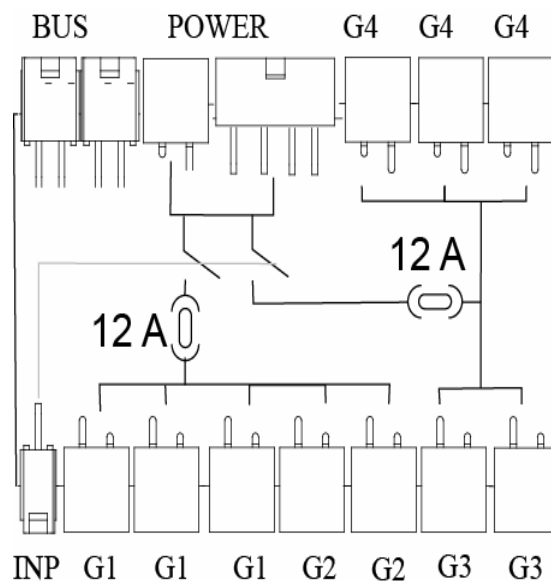

FEATURES OF NODE Model NSA10

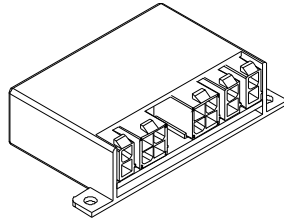

Model NSA 10

This system allows the delivery of power on a load, such as the water pump, that is connected to its output, but also the protection of it against short circuits or abnormal overloads.

This node has a provision for detecting levels with discrete sensors (with 4 levels) and with two overflow sensors.

The device is controlled remotely via the control panel to switch the flow of energy to the pump on/off. The control panel displays the status (on/off) of the device and also the status of its protections and of the level sensors.

Note: in the event of a fault on the Bus connection, it would not be possible to communicate with the control panel, and therefore the pump would not be able to be supplied; for this reason, the node switches to the AUTONOMOUS operating mode and supplies power to the pump, which operates to customer requirements, provided that the level measured by “LEVELS” is above zero, otherwise the pump supply is cut off.

Inputs

The device, as shown in the Figure, essentially comprises two types of connectors. The BUS connector for device supply and communication with the control panel; the 4-pin LEVELS connector usually used to detect the levels of a tank with a discrete sensor with four levels and connectors R1 and R2 with 2 pins, used to detect the overflow signal from two separate tanks.

Outputs

The output is the OUT connector, which directly controls the pump supply.

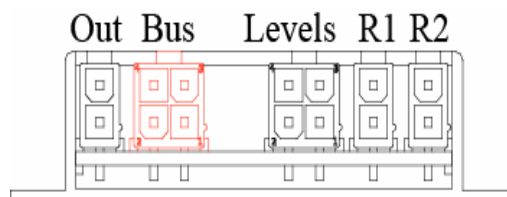

Electrical Specifications

The electrical specifications of the device are the following:

- Supply voltage 12 V
- Bus, 4-pin input connector, capacity 5 A
- Out, pump output protected with SMART 3 A fuse.
- Levels, input for sensor with 4 rods
- R1 and R2 two connectors for the level sensors.

Connectors

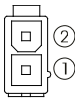
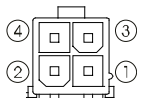
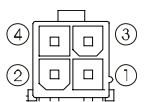
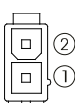
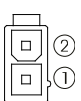
Connector (front)	Type	Name	Direction	Pin-Out
	Molex <i>"mini-fit Jr"</i> MLX5569-02A2	OUT	OUT	Pump between contacts 1 and 2
	Molex <i>"mini-fit Jr"</i> MLX5569-04	BUS	IN/OUT	1. Bus B 2. Ground 3. Bus A 4. Positive +12 V
	Molex <i>"mini-fit Jr"</i> MLX5569-04	LEVELS	IN	1. Level 1 1. Level 2 3. Level 3 4. Level 4
	Molex <i>"mini-fit Jr"</i> MLX5569-02A2	R1	IN	Level between contacts 1 and 2
	Molex <i>"mini-fit Jr"</i> MLX5569-02A2	R2	IN	Level between contacts 1 and 2

SOLUTION TO THE MORE COMMON PROBLEMS

IF THE FOLLOWING OCCURS	WHAT TO CHECKAND....DO
The Services Battery is not recharging with the vehicle on the move.	<ul style="list-style-type: none"> • Check the engine battery fuse (80 A reed in the black box on the battery positive terminal); • Check that the battery connectors are correctly inserted in the Power Link; • Check the condition of the 3 A fuse at the mechanical unit alternator output; • Check that the “engine on¹” signal on the mechanical unit alternator output, commonly called D+) is picked up correctly and reaches the input of the Power Link; • Check that when the engine is on the voltage of the engine and services batteries is the same (around 13.5 V); this can be done in two ways: by reading the voltage of the services and engine batteries directly on the control unit (LCD model), or measuring the voltage directly on their terminals. • Turn to qualified personnel.
There is no current on “the whole” living quarters (including the control unit).	<ul style="list-style-type: none"> • Check the condition of the 80 A reed fuse not near the services battery positive terminal; • Check that the services battery is charged; • Check that current reaches the living quarters with the engine on or with the 220 V supply on; if so, the services battery could be run down or damaged. • Turn to qualified personnel.
The fridge is not working with the engine on.	<ul style="list-style-type: none"> • Check the correct position of the fridge output connectors on the power link; • Check the “engine on” signal (D+) (3A engine compartment); • Check that the power link fridge output is not shorted or has a cut-off wire; • Check that the “engine on” signal (engine alternator) is picked up correctly and reaches the power supply unit input. • Check the connections to the fridge and to the power link respectively, following the instructions given in the description of the power link and in the Fridge instructions. • Turn to qualified personnel.
The fridge works at 12 V with the engine off.	<ul style="list-style-type: none"> • Check that the connections respectively to the fridge and to the power link are correct (take care not to exchange the +12 wire with the D+ wire especially on

¹ The “engine on” signal that reaches the power supply unit is usually picked up by the alternator output of the vehicle mechanical unit; in some mechanical units there might be more than one wire at the alternator output, so make sure that the signal is picked up by the right one. In other mechanical units, this signal is picked up by the ignition key.

IF THE FOLLOWING OCCURS	WHAT TO CHECKAND....DO
	<p>AES models);</p> <ul style="list-style-type: none"> • Check that the “engine on” signal is picked up correctly and reaches the input of the power link following the instructions given in the fridge section and instructions; • Replace the power supply unit and see if the problem persists; • Turn to qualified personnel.
The water pump cannot be controlled from the control unit.	<ul style="list-style-type: none"> • Check in the pump advanced menu (in the control units in which it is present) that the protection has not been activated which prevents it from turning on in the lack of water in the tank; • Check for moisture on the pump node due to a water leak and try drying it; • Check the correct position of the cables on the drain node (according to the instructions); • Check whether the other floor services (boiler, cassette, heater) are working properly, i.e. if the floor distributor, usually near the power supply unit, is working properly. • Check that the pump supply is not shorted (by the control unit); • Check that the pump can be controlled by the local switch (not fitted on all models); • Check whether the fault persists also after system reset; • Turn to qualified personnel.
The water levels are not indicated properly.	<ul style="list-style-type: none"> • Check that the sensor has been connected to the pump node as specified; • Check that the electrodes of the level sensor are not dirty²; • Turn to qualified personnel.
The lightning is not displayed when connecting to the 220V mains.	<ul style="list-style-type: none"> • Check that the power supply unit plug is correctly inserted in its socket; • Check that the differential circuit breaker is “armed”; • Check whether this is the only fault, or for example whether the pump is switched on from the control unit; • Turn to qualified personnel.
The ceiling lights do not turn on.	<ul style="list-style-type: none"> • Check that the riser line is not shorted and the power supply unit supplies power at the output; • Check that the ceiling distributor is on using the control button at the vehicle entrance; • Check on the advanced menu for the presence of the ceiling distributor;

² For this purpose you are recommended to keep the four-level sensor electrodes clean.

IF THE FOLLOWING OCCURS	WHAT TO CHECKAND....DO
The floor services are not powered.	<ul style="list-style-type: none"> • Turn to qualified personnel. • Check that the riser line is not shorted and that the power link supplies power at the output; • Check whether it is possible to control the power Link, usually near the power supply unit, through the local control button. • Turn to qualified personnel.
The current indicated on the control unit, though all the living quarter loads have been switched off, is other than zero Amperes.	<ul style="list-style-type: none"> • Make sure the solar panels, if fitted, have been switched off; • Check directly on the services battery if it is delivering current (to do this, insert an ammeter in series with the wire connected to the services battery positive terminal). • Reset the current from the menu. • Turn to qualified personnel.